



FEATURES

- small size, light weight
- Switching capacity up to 20A (at 85°C)
- High resistance to vibration and shock
- Outline dimensions: 15.5×12.2×13.6mm

CHARACTERISTICS

Contact arrangement	(1A)(1B)(1C)
Voltage drop (initial) ¹⁾	Typ:100mV(at 10A)
	Max.:250mV(at 10A)
Max.carrying current(NO contact)	35A/min 25A/h ²⁾
Max.switching current	NO/NC:35/20A(at 16VDC)
Max.switching voltage	60VDC
Max.switching power	280W
Contact rating	Resistive:20A 14VDC
	Motor locked:20A 14VDC
	Motor free:Break:4A 14VDC Shock:20A 14VDC
Min.contact load	1A 16VDC
Electrical life	1×10 ⁵ ops
Mechanical life	1×10 ⁷ ops 300ops/min
Initial insulation resistance	100MΩ (100VDC)
Dielectric strength	500VAC (1min)
	500VAC (1min,leakage current less than 1mA)
Operate time	Max:10ms
Release time	Max:5ms
Ambient temperature	-40°C~+85°C
Storage temperature	-40°C~+85°C
Vibration resistance	10Hz~55Hz 1.5mm
	10Hz to 55Hz 1.5mmDA
Shock resistance	Functional:100m/s ² (10g)
	Destructive:1000m/s ² (100g)
Termination	PCB
Construction	Sealed , Flux proofed
Unit weight	Approx:6g

1)Equivalent to the max,initial contact resistance is 100mΩ (1A 24VDC);

2)25°C,measured when coil is energized with 100% nominal voltage;

COIL DATA

at 23°C

Normal voltage (VDC)	Pick-up voltage (VDC)		Drop-out voltage (VDC)	Coil resistance (Ω ±10%)	Power consumption (W)
	20°C	85°C			
6	3.6	4.5	0.5	60	0.6
9	5.4	6.8	0.7	135	0.6
12	7.3	9.0	1.0	240	0.6
18	10.8	13.5	1.5	540	0.6
6	3.6	4.5	0.5	45	0.8
9	5.4	6.8	0.7	100	0.8
12	7.3	9.0	1.0	180	0.8
18	10.8	13.5	1.6	405	0.8
24	14.4	18.0	2.2	720	0.8

ORDERING INFORMATION

Type	MAD	-S-	1	12	-C
Construction	S-sealed nil-Fluxproof				
Contact group	1 : 1group				
Coil voltage	6, 9, 12, 18, 24VDC				
Contact form	A-NO B-NC C-NO/NC				

EXTERNAL DIMENSIONS

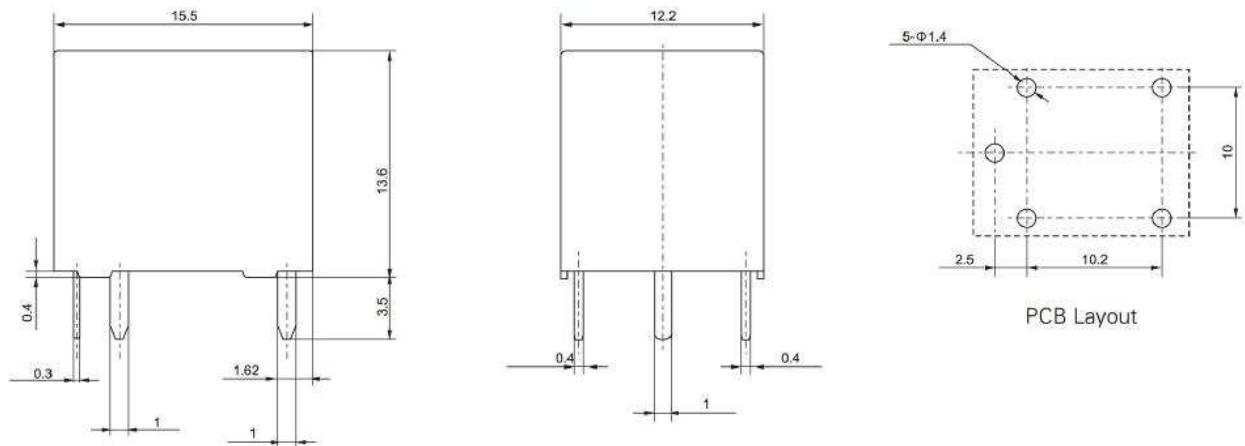

WIRING DIAGRAM

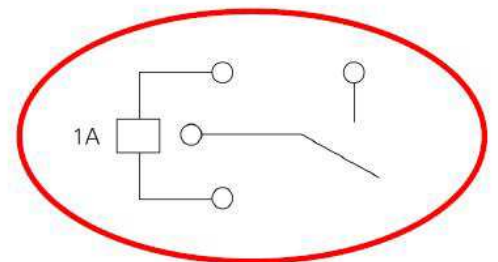
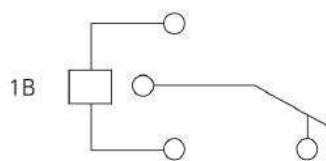
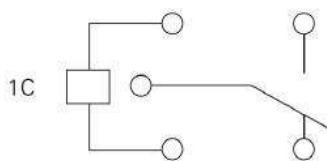

- Remark: 1) In case of no tolerance shown in outline dimension: outline dimension ≤ 1 mm, tolerance should be ± 0.2 mm; outline dimension > 1 mm and ≤ 5 mm, tolerance should be ± 0.3 mm; outline dimension > 5 mm, tolerance should be ± 0.4 mm.
 2) The tolerance without indicating for PCB layout is always ± 0.1 mm.